



## **STANDARD 4: HEATING, VENTILATION AND AIR CONDITIONING**

REVISED SEPTEMBER 2005, RESOLUTION 03-05-20

REVISED FEBRUARY 2006, RESOLUTION 03-06-09

REVISED SEPTEMBER 2006, RESOLUTION 03-06-40

REVISED JULY 2010, RESOLUTION 03-10-100

GENERAL REQUIREMENTS REVISED APRIL 2011, RESOLUTION 03-11-49

REVISED SEPTEMBER 2013, RESOLUTION 03-13-98

REVISED JULY 2015, RESOLUTION 03-15-101

REVISED JANUARY 2018, RESOLUTION 03-18-13

REVISED JULY 2019, RESOLUTION 03-19-71

REVISED MARCH 2023, RESOLUTION 03-23-23

REVISED June 2023, RESOLUTION 03-23-68

REVISED March 2025, RESOLUTION 03-25-57

### **1.0 GENERAL REQUIREMENTS**

**SEE STANDARD 1: GENERAL REQUIREMENTS**

### **2.0 DEFINITIONS**

The following definitions are oriented to situations typical in Laguna Woods Village.

**2.1 HVAC:** Heating, ventilation and air conditioning system.

**2.2 FORCED-AIR CENTRAL SPLIT SYSTEM:** A ducted system that provides both heating (heat pump) and cooling. The system consists of an outdoor unit (condenser) and an indoor unit (air handler), located in the attic or a closet. The ductwork for this type of system is typically located in the attic space. Air

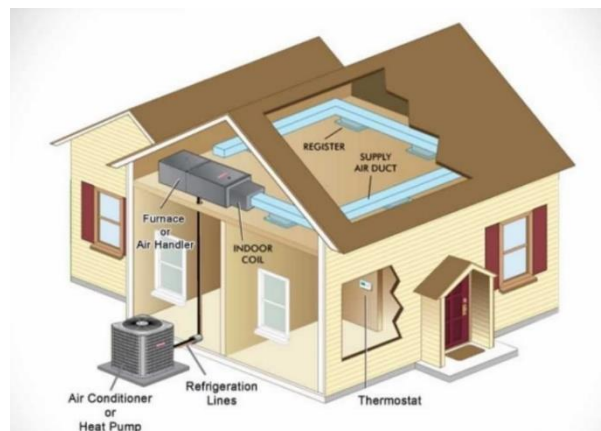

supply registers are located in each room with one return air grill centrally located.

- 2.3 MINI SPLIT DUCTLESS SYSTEM:** A system that provides both heating (heat pump) and cooling without the use of ducts. The system consists of one outdoor unit (compressor/condenser) and one to four room oriented indoor units (air handlers/evaporators). Each indoor unit has separate temperature controls.

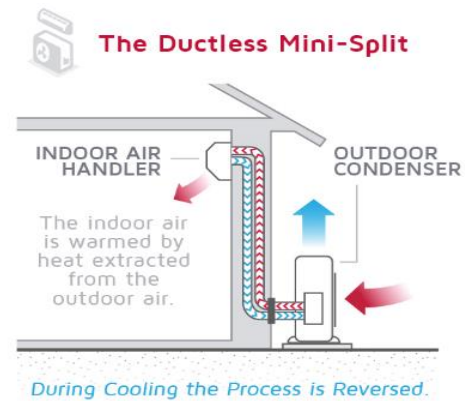

- 2.4 THROUGH THE WALL UNITS:** A self-contained unit framed and mounted through an opening in the wall. There are several variations:

A. PTAC: Packaged Terminal Air Conditioner. Able to provide both heating and cooling.

B. Air Conditioners:

1. Units that provide cooling only.
2. Units that provide cooling and electric heat (heat pump) (lower BTU capacity)
3. Units that provide cooling with a heat pump (higher BTU capacity)



**2.5 SEER:** Seasonal Energy Efficiency Ratio – a rating that measures how efficiently an air conditioner operates.

**2.6 HSPF:** Heating Seasonal Performance Factor – a rating used to measure the heating efficiency of a Heat Pump.

**2.7 dB:** Decibel a unit used to measure the intensity of a sound.

**2.8 CATWALK:** a narrow access way to support a technician in an attic space, used for servicing equipment.

**2.9 CHASEWAY:** An enclosure through which equipment piping is run to connect an exterior component to an interior component.

### 3.0 **APPLICATIONS**

- 3.1 All new installations and changeout of HVAC equipment require a mutual consent.
- 3.2 Architectural scaled floorplans indicating all details and component locations are required.
  - A. Architectural and/or engineering plans and details are required for all modifications to the existing buildings structural components.
    - 1. Modifications to existing building truss systems are prohibited.
  - B. All manufacturers unit system specifications are required with submittal.
- 3.3 Asbestos abatement may be required. Any interior modifications will require a review by the City of Laguna Woods Building Department.
- 3.4 Air-source heat pumps SEER and HSPF ratings must comply with current California Energy Codes.
- 3.5 All HVAC systems must be properly sized for the space to be conditioned. Oversizing may be detrimental to performance and efficiency. Verify manufacturer specification recommendations and or system requirements with the HVAC contractor.
  - A. Only one HVAC forced air split system or mini split system is allowed per manor.
- 3.6 All “package” units containing both heating and cooling in one system are prohibited due to system sizing.

Typical sizing for three-ton system  
74" wide by 48"  
deep by 40" high



- 3.7 Equipment Locations: All exterior equipment locations to be reviewed and approved in the mutual consent review process.
  - A. All forced air condenser units and condensers located on ground floor must be within 24" of the building wall and mounted on a manufactured non-metallic pad.
    - 1. Units must maintain sufficient clearance from windows,

other equipment, utility boxes, vents and walkways as per current California Building Code requirements.

2. All locations visible to two or more residential buildings or public walkways must provide an aesthetic landscaping enclosure. Design, layout, and installation to be determined by the mutual's landscape department at the members expense. A landscape request form must be included in the submittal package.
3. All existing landscape and irrigation revisions required to accommodate ground level locations must be performed by the mutual's landscape department at the members expense. A landscape request form must be included in the submittal package.

B. Mini split condenser can be installed on a balcony provided there is sufficient physical floor / wall space and provided there is space to meet manufacturer's operational clearance requirements.

1. See Section 7.3 Building Maintenance Requirements

C. Physical space dependent, all top floor manors may roof mount condensing units on flat roofs provided that the installation conforms to the following requirements:

1. Structural review and documentation by a licensed architect or engineer will be required for verification of existing roof to support new HVAC unit.
2. Units must be on a raised platform per Section 8.
3. All roof penetrations to be performed by a licensed roofing contractor. Roofing contractor information to be supplied with mutual consent submittal.
  - a. If a PVC roof is still under installation warranty (installed within the last five years) the member must use the company supplying the warranty for any roofing repairs.

(1) Manufacturer's Warranty: All roofing repairs require a Johns Manville certification.

4. Proposed roof locations can not impede on space allocation for solar panel installations.

**3.8** All exterior units must have a manufacture's specification rating while operating of 65 db. or less.

**3.9** Exposed exterior electrical conduit and boxes can run a maximum of 15 feet and must be painted to match the surface it is attached to.

**3.10** Chaseway Requirements:

A. Exterior Chaseways:

1. All exterior components that connect the exterior unit to the interior unit must be encased in a single, half round, square or rectangular sheet metal two-piece chaseway. Chaseway to be painted to match the color of the wall to which it is attached.
2. Water tight seals must be provided around all penetrations.
3. The chaseway must be made rodent proof by installing wire mesh at the bottom of the chaseway. The use of steel wool is not allowed. Pest control expanding foam may be installed in addition to the wire mesh as long as it is properly trimmed without any visible overflow.
4. The length of chaseway runs are limited. Vertical: May not exceed the minimum length needed to reach the ceiling/attic space of the manor. Horizontal: May not exceed a maximum of 15 feet. All chaseway runs must be indicated on floorplan and elevations.
  - a. Any exceptions will require a variance.
5. Cornice Moldings: If cutting of cornice moldings are required; removing the effected section of molding, cutting the metal flashing at both ends, applying sealant under the metal flashing, bending the metal flashing to be flush with the wall and fastening the metal flashing in place using screws. Apply sealant as needed. Seal the cut ends of the cornice moldings.

B. Interior Chaseways:

1. Components cannot run exposed.
2. Components can be run:
  - a. Through attic space
  - b. In wall cavities
  - c. Behind crown molding
3. Exceptions will be subject to review and may require a variance.

**3.11** In no case are any HVAC modifications to leave a manor without a heat source.

#### **4.0 FORCED AIR CENTRAL SPLIT SYSTEMS**

##### **4.1** Air Handler Requirements:

- A. Attic installation to include installation of attic light and sufficient catwalk to equipment to allow for repair or replacement.
- B. Water Heater Closets: For air handlers installed in water heater closets, the closet must be of sufficient size of allow for unit servicing and provide for proper ventilation of return air.

#### **5.0 MINI SPLIT DUCTLESS SYSTEMS**

**5.1** See Section 3.9 for all chaseway requirements.

#### **6.0 THRU WALL UNITS**

**6.1** Window mounted units are prohibited.

**6.2** All through wall units to have condensate evaporators. Exceptions subject to review and approval through Manor Alterations plan review process.

**6.3** New replacement units to be installed in existing knock-out framed areas.

- A. Alternate location requests must be reviewed and approved through the Manor Alterations plan review process. Consideration will be given to proximity of adjoining manors and overall building aesthetics.
- B. Units may not be located or project into any walkway, breezeway or interior court of a multi-unit building.
- C. In the event an existing sleeve location is not reused:
  - 1. The interior opening is to be insulated and patched as necessary to maintain the waterproof integrity of the wall. Finish to match the existing interior finish.
  - 2. The exterior framework and grill can remain. Paint to match exterior surroundings.

## **7.0 MAINTENANCE & OWNERSHIP**

**7.1** The member is responsible for all direct and indirect costs associated with HVAC systems modifications and installations.

**7.2** The member is responsible for all costs associated with on-going maintenance and appearance of HVAC systems. The mutual at its own discretion may undertake any perceived maintenance and appearance upkeep and charge the Member if HVAC systems are not properly maintained by member.

**7.3** Should it become necessary for ongoing building maintenance, the member will be responsible for removal and replacement of HVAC systems.

## **8.0 HVAC ROOF PLATFORM DETAILS**

See accompanied details:

**8.1** Wood Frame Platform

**8.2** Johns Manville Detail

8.1

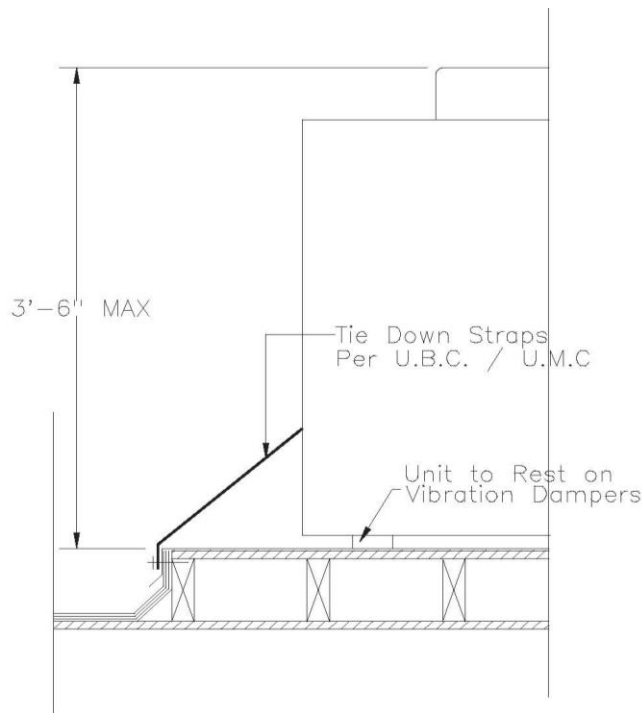

SECTION HVAC

HVAC2.DWG REV. 12/95 SCALE: 1"=1'0"

ROOFING NOTES

SPUD EXISTING ROOF AREA AROUND PLATFORM  
 A MINIMUM OF 2 FEET AWAY FROM EACH SIDE.  
 PRIMER PLATFORM SIDES, CANT STRIP, AND  
 SPUDED SURFACE W/ CON PRIME AT THE RATE 1gal per 100 SQ.FT

ROOF AS FOLLOWS PER 100 SQ.FT.  
 CONPLY TYPE A-IV(2LAYERS) . . . . . 22lbs PER 100 SQ.FT.  
 HMP ASPHALT (PLIES). . . . . 60lbs PER 100 SQ.FT.  
 CONCAP (1 LAYER). . . . . 75lbs PER 100 SQ.FT.  
 HMP ASPHALT (SURFACE). . . . . 25lbs PER 100 SQ.FT.  
 GRAVEL (1/4" - 1/2"). . . . . 400lbs PER 100 SQ.FT.

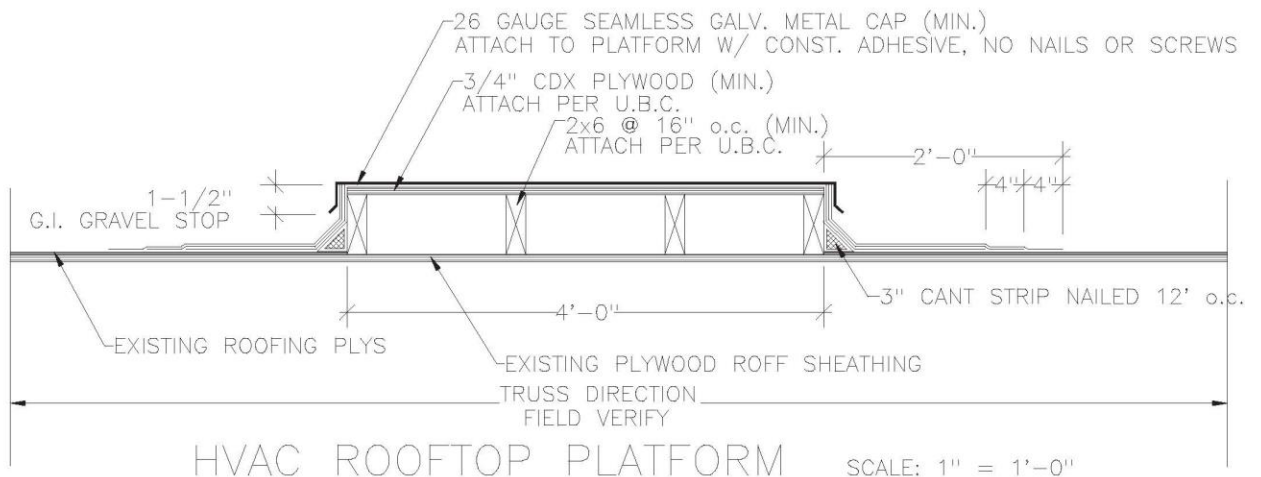

HVAC ROOFTOP PLATFORM

SCALE: 1" = 1'-0"



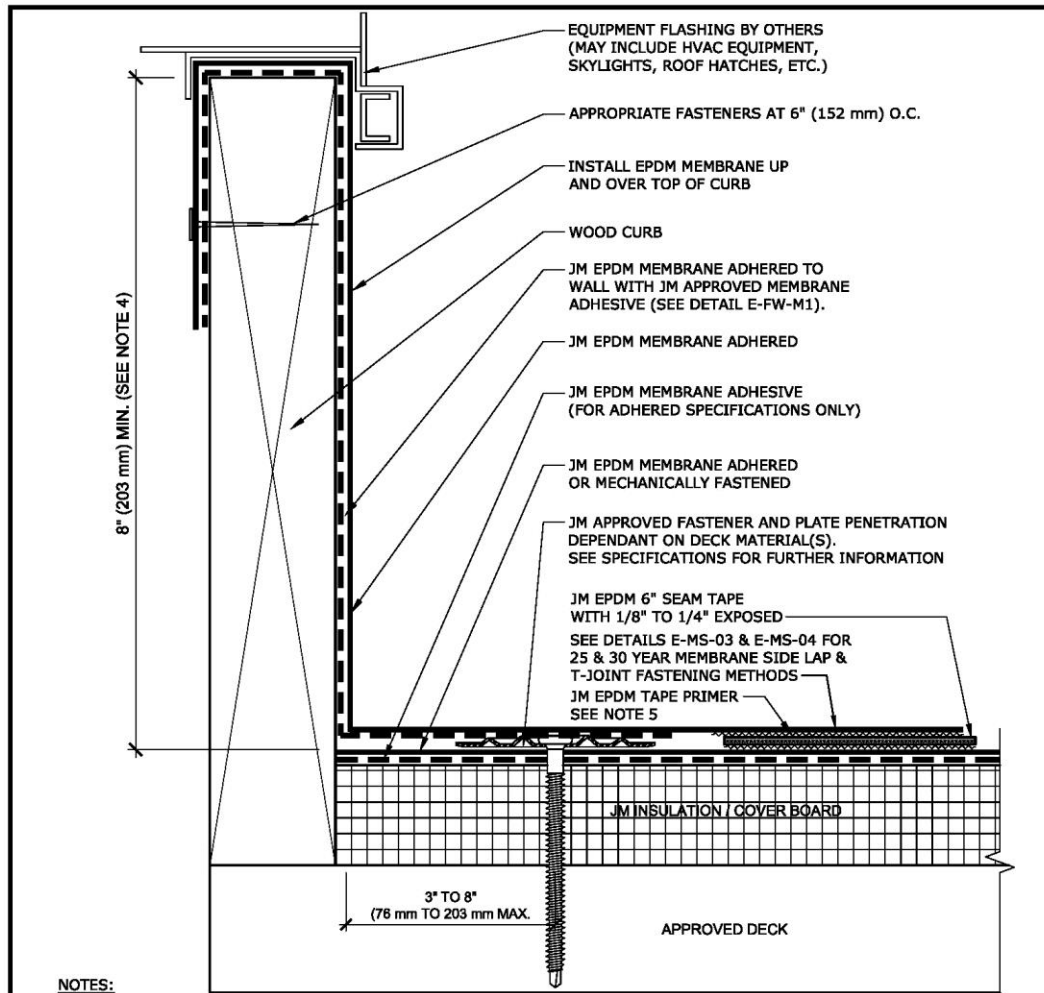

**NOTES:**

1. REFER TO JOHNS MANVILLE WEBSITE ([www.jm.com](http://www.jm.com)) FOR MOST UP-TO-DATE INFORMATION.
2. PLEASE SEE SINGLE PLY FLASHING SPECIFICATIONS FOR A FULL DESCRIPTION OF INSTALLATION INSTRUCTIONS AND REQUIREMENTS WHICH ARE CONSIDERED A PART OF THIS DETAIL.
3. ANY CARPENTRY OR METAL WORK SHOULD BE DESIGNED AND CONSTRUCTED IN ACCORDANCE WITH LOCAL CODE REQUIREMENTS AND/OR PROJECT SPECIFICATIONS. THESE COMPONENTS SHOULD BE REVIEWED AND APPROVED BY A LICENSED DESIGN PROFESSIONAL.
4. HEIGHT OF CURB TO BE ADJUSTED WITH NAILERS. IT IS PREFERRED TO RAISE CURB ONTO NAILERS TO EXTEND FLASHING HEIGHT.
5. JM EPDM TAPE PRIMER OR JM SINGLE PLY MEMBRANE PRIMER (LOW VOC) MUST BE APPLIED ON ALL SURFACES COMING INTO CONTACT WITH JM EPDM PEEL & STICK PRODUCTS. ROLL MEMBRANE WITH HAND ROLLER UNDER PRESSURE AT SEAM.
6. 1/8" TO 1/4" OF EPDM SEAM TAPE MUST BE EXPOSED.
7. REINFORCED JM EPDM MEMBRANE IS REQUIRED FOR MECHANICALLY FASTENED INSTALLATIONS ONLY.
8. SEE E-FW-B DETAILS FOR JM APPROVED BASE FLASHING TIE IN TERMINATION METHODS.

DRAWING NO.

**E-FC-12**

NEW DETAIL

**WOOD CURB BASE FLASHING**

MEMBRANE TYPE:  
JM EPDM

Johns Manville is a manufacturer of commercial roofing products and offers this general conceptual information to you as a courtesy. This complimentary assistance is not to be used or relied upon by anyone as a substitute for professional engineering design and documentation required by building code, contract, or applicable law. By accepting these comments you agree they do not constitute any representations, endorsements of, or an assumption by Johns Manville of any liability for either the adequacy of the design of this building or any other material not supplied by Johns Manville.



SCALE  
N.T.S

ISSUE DATE  
5-22-18

MAXIMUM GUARANTEE TERM:  
30 YEAR